



NSWK 系列 視窗型控制箱



材 料與結構

- 箱體、門蓋使用1.5mm鋼板
- 底板使用2.0mm鍍鋅鋼板
- 視窗使用5.0mm強化玻璃
- 右開
- 全焊式焊接
- 德國PU無縫墊圈
- 工業級強化後鈕
- 門鎖使用非石標準直角鎖
- 箱體預留壁掛用固定孔
- 接地螺絲植於箱體及門板內
- 附接地線包

表 面處理

- RAL 7032室內粉體塗裝

歐 美工業標準

- IEC 60529規範之IP66等級
- 符合歐盟RoHS指令

客 製化服務

- 開孔加工
- 客製門板與箱體
- 特殊零配件
- 特殊顏色
- 特殊尺寸
- 其他客製化服務請洽詢業務人員



NO.	目錄型號	尺寸		
		H(mm)	W(mm)	D(mm)
1	NSWK 202015	200	200	150
2	NSWK 302015	300	200	150
3	NSWK 302515	300	250	150
4	NSWK 302520	300	250	200
5	NSWK 303015	300	300	150
6	NSWK 303020	300	300	200
7	NSWK 304015	300	400	150
8	NSWK 304020	300	400	200
9	NSWK 403015	400	300	150
10	NSWK 403020	400	300	200
11	NSWK 404020	400	400	200
12	NSWK 406020	400	600	200
13	NSWK 406025	400	600	250
14	NSWK 406030	400	600	300
15	NSWK 503015	500	300	150
16	NSWK 503020	500	300	200
17	NSWK 504015	500	400	150
18	NSWK 504020	500	400	200
19	NSWK 504025	500	400	250
20	NSWK 505020	500	500	200
21	NSWK 505025	500	500	250
22	NSWK 507020	500	700	200
23	NSWK 507025	500	700	250
24	NSWK 604020	600	400	200
25	NSWK 604025	600	400	250
26	NSWK 604030	600	400	300

NO.	目錄型號	尺寸		
		H(mm)	W(mm)	D(mm)
27	NSWK 605020	600	500	200
28	NSWK 605025	600	500	250
29	NSWK 606020	600	600	200
30	NSWK 606025	600	600	250
31	NSWK 606030	600	600	300
32	NSWK 705020	700	500	200
33	NSWK 705025	700	500	250
34	NSWK 806020	800	600	200
35	NSWK 806025	800	600	250
36	NSWK 806030	800	600	300
37	NSWK 808025	800	800	250
38	NSWK 808030	800	800	300
39	NSWK 1006025	1000	600	250
40	NSWK 1006030	1000	600	300
41	NSWK 1006040	1000	600	400
42	NSWK 1008025	1000	800	250
43	NSWK 1008030	1000	800	300
44	NSWK 1206030	1200	600	300
45	NSWK 1206040	1200	600	400
46	NSWK 1208030	1200	800	300

NO.	目錄型號	尺寸		
		H(mm)	W(mm)	D(mm)
47	NSWK-M	非標準尺寸		

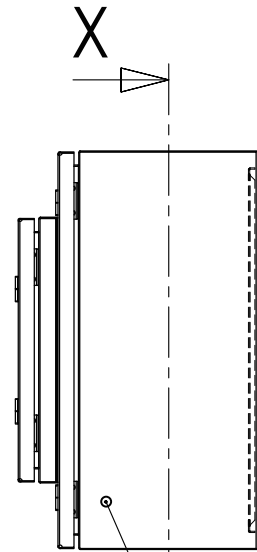
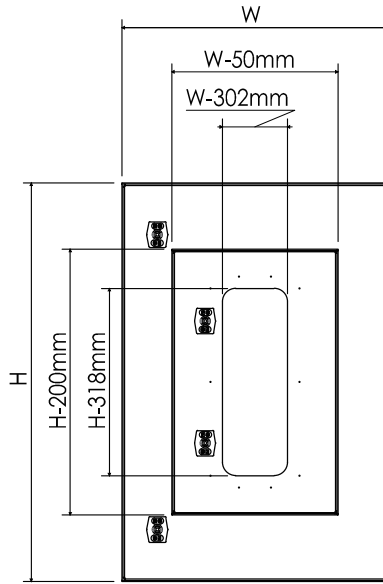
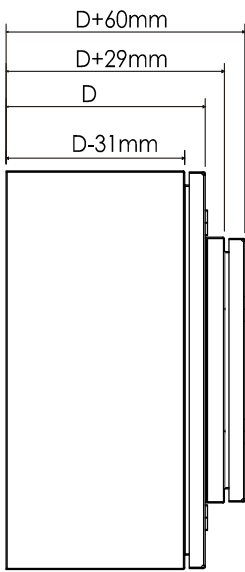

Earthing stud

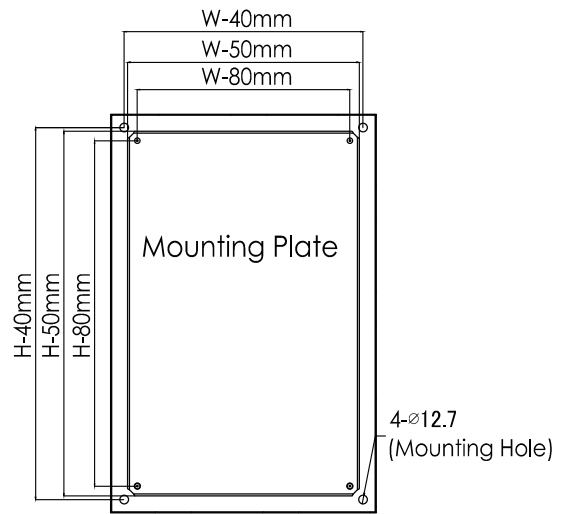
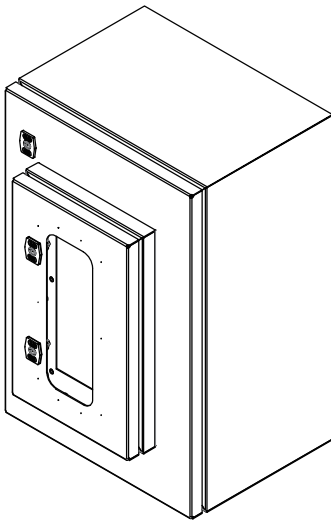

Section View X-X